

4

3

2

1

THIS DRAWING IS UNPUBLISHED. RELEASED FOR PUBLICATION, 19 .
 © COPYRIGHT 19 BY AMP INCORPORATED. ALL RIGHTS RESERVED.

LOC	DIST	REVISIONS			
P	LTR	DESCRIPTION	DATE	DWN	APVD
G	14	H	REV / 0L20-0014-96	28OCT96	ME TM

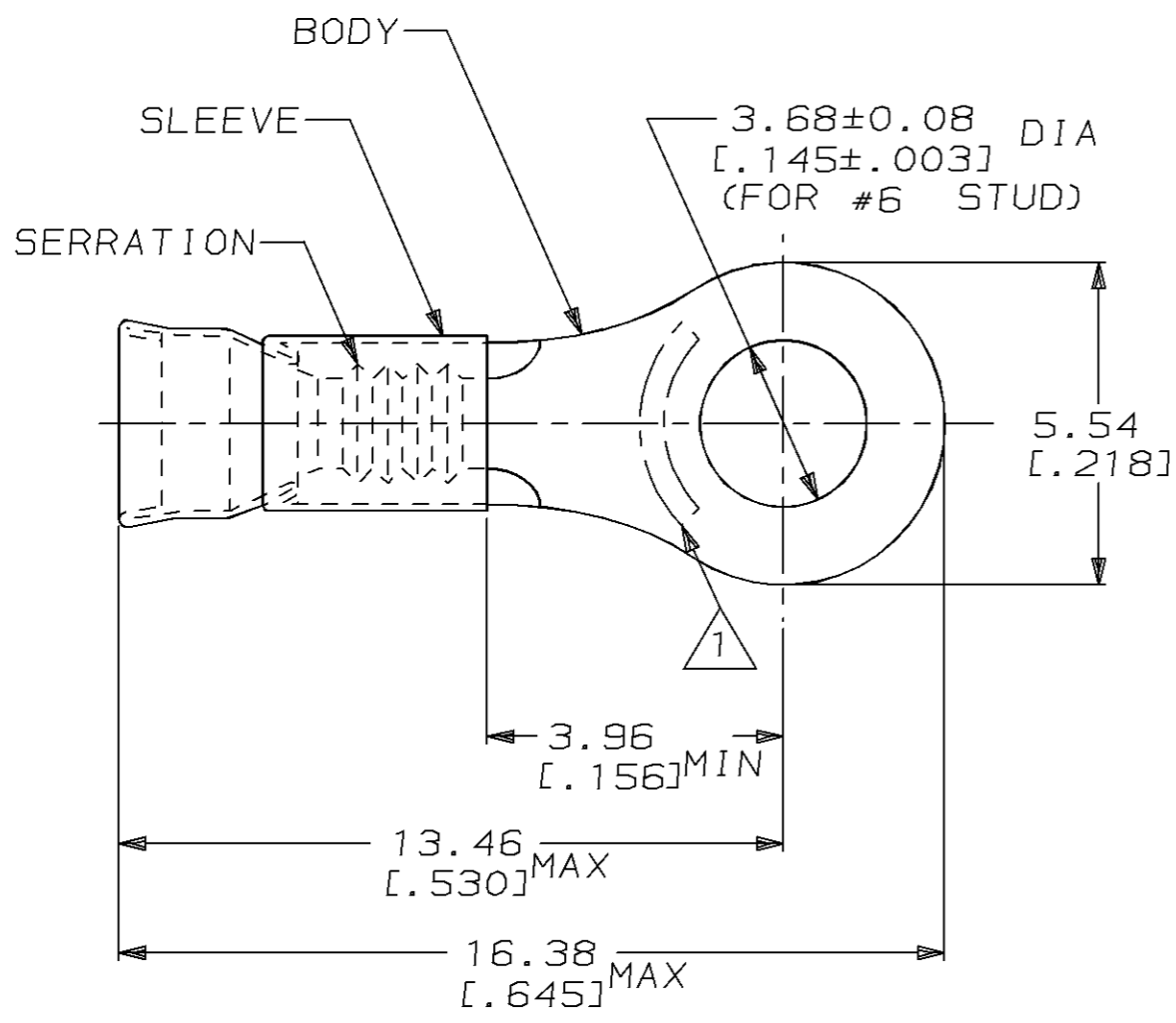

- 1. STAMP AMP 22-18* APPROX AS SHOWN
22-16 TERMINALS ARE STAMPED 22-18 IN ACCORDANCE WITH MILITARY SPEC MIL-T-7928 COMMERCIAL WIRE RANGE IS 22-16
- 2. WIRE INSUL DIA, 1.30-2.79 [0.051-.110]
- 3. TONGUE MATL THK, 0.79±0.05 [0.031±.002]
- 4. NICKEL PL PER QQ-N-290
- 5. GOLD PL PER MIL-G-45204 OVER NICKEL PL PER QQ-N-290

QTY	PACKAGE TYPE	PART NO
1000	LOOSE PIECE	△ 323151-1
1000	LOOSE PIECE	△ 323151

AMP INCORPORATED CUSTOMER SERVICE SYSTEM		MAX RECOMMENDED OPERATING TEMPERATURE: 343°C [650°F]		THIS DRAWING IS A CONTROLLED DOCUMENT FOR AMP INCORPORATED. IT IS SUBJECT TO CHANGE AND THE CONTROLLING ENGINEERING ORGANIZATION SHOULD BE CONTACTED FOR THE LATEST REVISION.		DWN L OLMEDA 100CT94		AMP Incorporated	
FOR ADDITIONAL PRODUCT INFORMATION OR COPIES OF DRAWINGS AND TECHNICAL DOCUMENTS		PRODUCT INFORMATION CENTER 1-800-522-6752		DIMENSIONS: mm [in]		TOLERANCES UNLESS OTHERWISE SPECIFIED:		Harrisburg, PA 17105-3608	
FOR APPLICATION TOOLING INFORMATION		TOOLING ASSISTANCE CENTER 1-800-722-1111		VOLTAGE RATING: -		0 PLC ±- 1 PLC ±- 2 PLC ±0.20 [0.008] 3 PLC ±- 4 PLC ±- ANGLES ±-		NAME TERMINAL, RING TONGUE, STRATOTHERM, DIAMOND GRIP, WIRE SIZE, 22-16 AWG	
FOR ORDER ENTRY		1-800-526-5142		CIRCULAR MIL AREA: 0.26mm²-1.65mm² [509-3260]		MATERIAL BODY, CU PER ASTM B152 SLEEVE, NI SIL PER ASTM B122		DRAWING NO C-323151	
		STRANDED WIRE				FINISH SEE TABLE		SIZE A3 CAGE CODE 00779	
						WEIGHT -		SCALE 6:1 SHEET 1 OF 1 REV H	
						CUSTOMER DRAWING			

AMP 1470-19 REV 09MAY94